

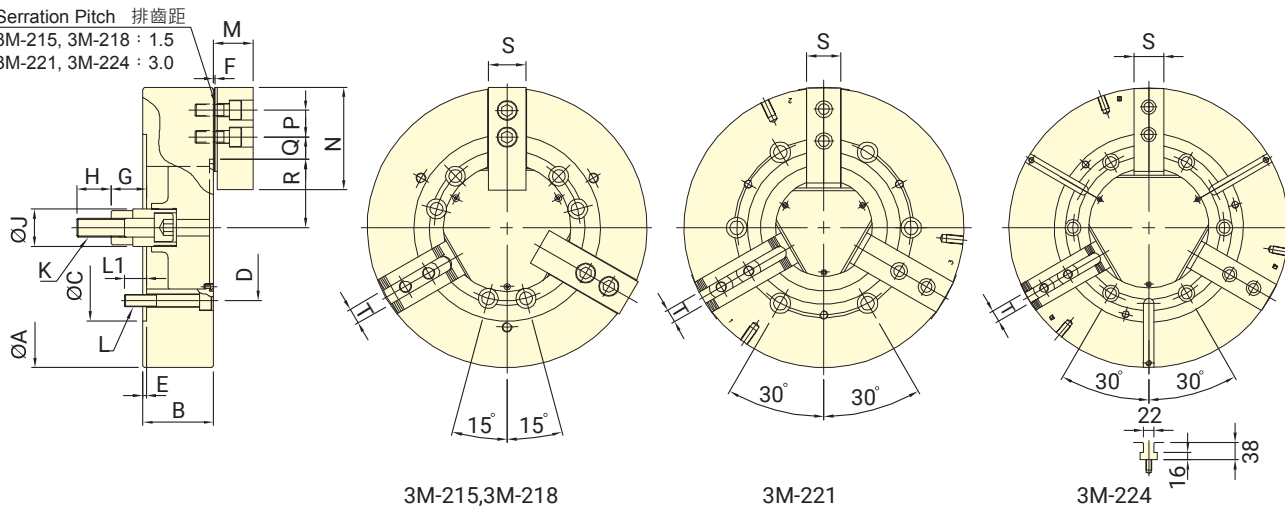

- 楔形三爪中實夾頭，超長爪行程。
- 摺動面均經硬化及精密研磨，並直接潤滑。
- 高剛性結構及高夾持精度。
- WEDGE-HOOK type 3-jaw power chuck and extra long jaw stroke.
- Matching surfaces of all parts hardened, ground and lubricated directly.
- High rigidity and high clamping accuracy.

Serration Pitch 排齒距  
 3M-215, 3M-218 : 1.5  
 3M-221, 3M-224 : 3.0



保留規格修改的權利  
 Subject to technical changes

### 技術規格 SPECIFICATIONS

型號 Model	楔心行程 Plunger stroke	爪行程 (直徑) Jaw stroke (Dia.)	夾持直徑 Chuck Dia.		容許油壓缸推力 Max. D.B. pull	最大夾持力 Max. Clamping force	最高迴轉數 Max. speed	I	重量 Weight	適用迴轉缸 Matching cyl.	最大使用壓力 Max. pressure
	mm	mm	最大 mm	最小 mm	kN (kgf)	kN (kgf)	min <sup>-1</sup> (r.p.m.)	kg-m <sup>2</sup>	kg		MPa (kgf/cm <sup>2</sup> )
3M-215	35	25.4	381	20	91.0(9280)	158.9(16200)	2300	1.8	96	RK-200(N)	3.0(30)
3M-218	35	25.4	450	51	91.0(9280)	158.9(16200)	2000	2.32	124	RK-200(N)	3.0(30)
3M-221	35	25.4	530	53	91.0(9280)	158.9(16200)	1350	4.9	175	RK-200(N)	3.0(30)
3M-224	35	25.4	610	160	91.0(9280)	158.9(16200)	1250	7.2	225	RK-200(N)	3.0(30)

### 外型尺寸 DIMENSIONS

Model	A	B	C(H6)	D	E	F	G max.	G min.	H	J
3M-215	381	114	300	235	6	2	104	69	55	60
3M-218	450	114	300	235	6	2	92	57	55	60
3M-221	530	125	380	330.2	6	3	97	62	55	60
3M-224	610	125	380	330.2	6	3	97	62	55	60

Model	K	L	L1	M	N	P	Q max.	Q min.	R max.	R min.	S	T
3M-215	M30x3.5	6~M20	30	63.3	165	43	49.75	18.25	79	66.3	62	25.5
3M-218	M30x3.5	6~M20	35	63.3	165	43	51.25	18.25	109.5	96.8	62	25.5
3M-221	M30x3.5	6~M24	31	71	180	60	90.5	24.5	92	79.3	65	25
3M-224	M30x3.5	6~M24	31	71	180	60	90	24	131	118.3	65	25