

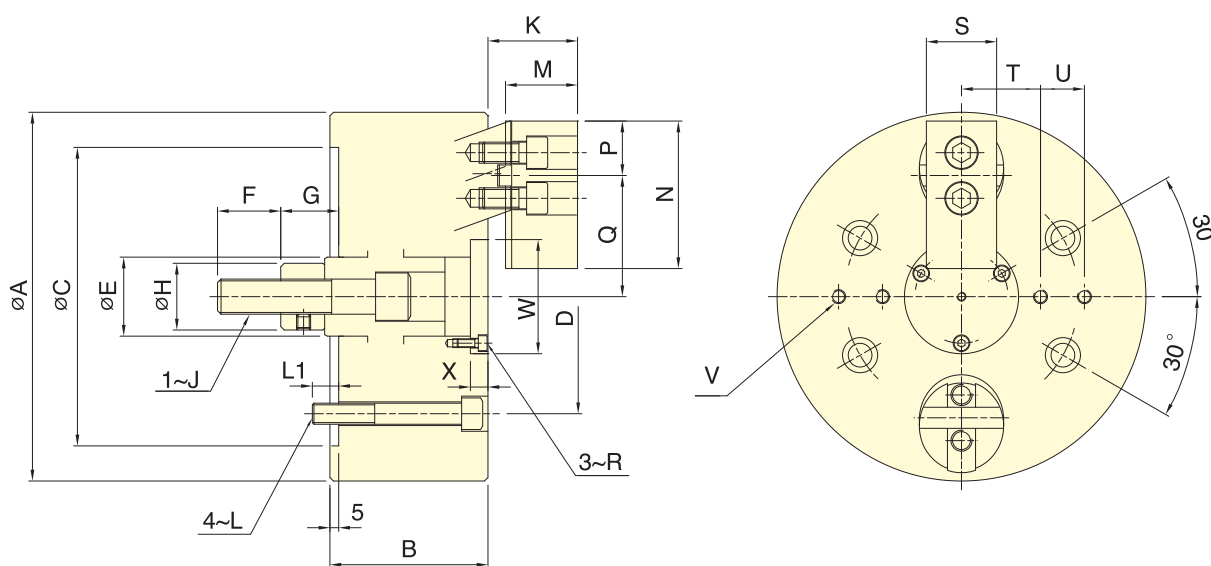

- 可同時將工件做徑向夾持與軸向後拉，使工件不上浮並緊貼座金基準面。
- 高剛性硬化處理的本體與圓柱後拉機構，並經過軸孔精搪，確保夾持精度與耐用度，適合重切削場合。
- Radial clamp and axial pull down at the same time, keep the workpiece attaching close to the base surface of the chuck.
- Almost no workpiece uplifting displacement.
- The body and the cylinder pull-down mechanism are heat-treated and fine boring, which guarantee the clamping precision and durability.
- Suitable for heavy duty machining.
- 氣密檢知 (選配)。
- Air-tight pressure detect function is optional.

特殊動力夾頭



保留規格修改的權利
Subject to technical changes

技術規格 SPECIFICATIONS

型號 Model	楔心行程 Plunger stroke mm	爪行程 (直徑) Jaw stroke (Dia.) mm	夾持直徑 Chuck Dia.		容許油壓缸 推力 Max. D.B. pull kN (kgf)	最大夾持力 Max. Clamping force kN (kgf)	最高迴轉數 Max. speed min ⁻¹ (r.p.m.)	I Moment of inertia kg·m ²	重量 Weight kg	適用迴轉缸 Matching cyl.	最大使用壓力 Max. pressure MPa (kgf/cm ²)
			最大 Max. mm	最小 Min. mm							
2D-06	10	7.2	165	22	10.0(1020)	16.7(1700)	3500	0.045	12	RK-100	1.4(14.3)
2D-08	10	7.2	210	28	16.7(1700)	30.0(3060)	3500	0.13	23	RK-125	1.5(15)
2D-10	15	10.8	254	35	23.3(2379)	40.0(4079)	2500	0.34	43	RK-125	2.1(21.1)

外型尺寸 DIMENSIONS

Model	A	B	C	D	E	F	G max.	G min.	H	J	K max.	K min.	L
2D-06	165	85	140	104.8	35	36	37	27	32	M16	45	35	M10
2D-08	210	90	170	133.4	45	36	38	28	38	M20	56	46	M12
2D-10	254	110	220	171.5	55	46	47	32	50	M24	65	50	M16

Model	L1	M	N	P	Q max.	Q min.	R	S	T	U	V	W	X
2D-06	16	31	70	27	57.7	54.3	M4	35	35	20	4~M6	52	7
2D-08	15	41	84	31	70.8	67.2	M5	40	45	25	4~M8	65	10
2D-10	24	46	100	38	85	79.6	M6	50	55	30	4~M8	75	12